

- ІНСТРУКЦІЯ З ЕКСПЛУАТАЦІЇ ВІТРИНИ ХОЛОДИЛЬНОЇ - OPERATING MANUAL



Ua Інструкція з експлуатації
вітрини холодительної

En Operating manual

Pl Instrukcja obsługi
gabloty chłodniczej

Table of contents

| | |
|--|----|
| Model type | 3 |
| 1. SAFETY | 4 |
| 1.1. GENERAL INFORMATION | 4 |
| 1.2. LIMITATION OF LIABILITY | 4 |
| 1.3. EXPLANATION OF SYMBOLS | 5 |
| 1.4. SAFETY INSTRUCTIONS AND WARNINGS. | 6 |
| 2.1. STANDARDS AND DIRECTIVES | 8 |
| 2.2. TECHNICAL DATA | 9 |
| 2. 3 . PACKAGE AND FUNCTIONS | 10 |
| 2.4. AUTOMATIC DEFROSTING | 11 |
| 3. OPERATING AND DISPLAY ELEMENTS | 12 |
| 3.1. MECHANICAL THERMOSTAT | 13 |
| 3.2. ELECTRONIC TEMPERATURE REGULATOR DANFOSS | 13 |
| 3.3. ELECTRONIC TEMPERATURE REGULATOR ELIWELL | 16 |
| 4. UNPACKING AND INSTALLATION | 17 |
| 4.1. PROCEDURE FOR ASSEMBLY OF INTERNAL GRILLS. | 17 |
| 4.2. LOCATION AND ASSEMBLY PROCEDURE IN THE "ISLAND" SCHEME | 20 |
| 5. LOADING | 23 |
| 6. DECOMMISSIONING AND STORAGE. | 24 |
| 7. CLEANING | 24 |
| 8. DISPOSAL | 26 |

Model type

| Model | Volume, l | External dimensions, mm WxDxH | Temperature range, °C | Net weight |
|--------------------------------------|--------------|-------------------------------------|--------------------------|---------------|
| "Frost Stream" Hermes 1.45 | 645 | 1450x860x950 | -18..-23 | 135 |
| "Frost Stream" Hermes 1. 85 | 860 | 1850x860x950 | -18..-23/ -5..+5 | 144 |
| "Frost Stream" Hermes 1. 85 (low) | 680 | 1850x860x820 | -18..-23/ -5..+5 | 140 |
| "Frost Stream" Hermes 2.1 | 994 | 2100x860x950 | -18..-23/ -5..+5 | 161 |
| "Frost Stream" Hermes 2.5 | 1209 | 2500x860x950 | -18..-23/ -5..+5 | 184 |
| "Frost Stream" Hermes X | 1070 | 2100x1000x896 | -18..-23 | 148 |
| "Frost Stream" Titan 1.45 | 696 | 1450x860x940 | -18..-23 | 107 |
| "Frost Stream" Titan 1.85 | 825 | 1850x860x940 | -18..-23/ -5..+5 | 116 |
| "Frost Stream" Titan 2.1 | 955 | 2100x860x940 | -18..-23/ -5..+5 | 133 |
| "Frost Stream" Titan 2.5 | 1160 | 2500x860x940 | -18..-23/ -5..+5 | 156 |
| "Frost Stream" Titan X | 704 | 1330x1000x940 | -18..-23 | 115 |
| "Frost Stream" Zeus 1.45 | 596 | 1450x860x936 | -18..-23 | 130 |
| "Frost Stream" Zeus 1.85 | 797 | 1850x860x936 | -18..-23/ -5..+5 | 139 |
| "Frost Stream" Zeus 2.1 | 923 | 2100x860x936 | -18..-23/ -5..+5 | 162 |
| "Frost Stream" Zeus 2.5 | 1124 | 2500x860x936 | -18..-23/ -5..+5 | 193 |

1. SECURITY

1.1. GENERAL INFORMATION

This operating manual is part of the equipment and ensures safe and efficient operation.

Carefully read this instruction manual before using the equipment, and pass it on to other persons who are entrusted with the operation and maintenance of this equipment.

Make sure that the manual is read and understood by the people involved in the operation and maintenance of the equipment.

Make sure that the operating instructions are available and in an accessible place.

Only trained personnel may operate and clean the equipment. Only a qualified technician authorized by the manufacturer may carry out maintenance and repairs.

1.2. LIMITATION OF LIABILITY

All information in this manual was compiled taking into account current standards and legal norms, as well as empirical values of the manufacturer. The manufacturer is not responsible for damage to people or property (equipment, goods, etc.) resulting from:

- Failure to comply with the instructions and safety rules contained therein;





- Failure to comply with safety regulations;
- Improper use;
- Engagement of untrained operational and service personnel;
- Unauthorized conversion and technical changes by the customer on his own;
- Use of spare parts not approved by the manufacturer;
- Malfunction of the power supply or electrical safety devices.



Failure to comply with the above points may also void the warranty.

The manufacturer reserves the right to make technical changes to optimize and improve the efficiency of the equipment.

1.3. EXPLANATION OF SYMBOLS

Safety instructions and warnings are indicated in the manual with symbols and signal words. Signal words indicate the degree of risk.

| Symbol | Explanation |
|---|--|
|  WARNING | Danger of medium degree. Can result in serious injury or death |
|  CAUTION | A hazard with a low degree of risk |
|  Notification | Individual information or general important information to avoid property damage |
|  Electric voltage | Electric voltage |

| | | |
|--|---|--|
|  | <p>Flammable substances</p> | <p>Substances ignite from a slight heating, a small fire source</p> |
|  | <p>Separate collection of electrical and electronic equipment</p> | <p>Special disposal is not allowed throw away together with the rest of the waste, for processing requires special conditions.</p> |

1.4. SAFETY INSTRUCTIONS AND WARNINGS.



WARNING



- Never connect damaged equipment to the mains. In this case, immediately contact the manufacturer's service department. Otherwise, there is a risk of electric shock or refrigerant leakage.



- Do not use multiple outlet blocks or extension cords. Thermal overload occurs, creating a risk of smoldering/burning and electric shock.

- Do not under any circumstances remove the protective devices or covers attached to the device by the manufacturer. There is a risk of injury from moving parts or voltage.
- Do not make technical changes to the equipment. Otherwise, there is a risk of injury or electric shock.
- Damaged network cables can only be replaced by an authorized service technician. Otherwise, there is a risk of electric shock.
- Before starting work with the electrical system and the cooling system, it is necessary to disconnect the cable from the equipment network. Otherwise, there is a risk of electric shock.

- Hot steam and water under high pressure or high temperature can damage electrical insulation, electronic parts and the refrigerant circuit. Therefore, do not use hot steam, high temperature or high pressure water.



CAUTION

- When loading freezers with products, there is a risk of frostbite. Therefore, use protective gloves.
- The sharp edges of the device can cut your hands during cleaning. Therefore, use protective gloves.
- Mechanical damage to the device, for example caused by product carts that do not disrupt the technical function, must be repaired by the store operator. In the event of damage to the cooling system or the electrical system, the service department must be notified immediately. There is a risk of injury.



Notification

- The equipment can be transported, stored and used only in a horizontal position, standing on the designated rollers or legs.
- Inspect the equipment for shipping damage and test it for functionality immediately after delivery. If you find any defects, contact the manufacturer's service department immediately.
- The equipment must be operated in the climatic class indicated on the rating plate ([Chapter 2.2](#)). Operation above the values indicated in the climate class will lead to a decrease in energy efficiency and productivity.
- Do not expose the equipment to direct sunlight or high-temperature radiators.
- For the correct operation of the equipment, the ambient temperature should not be below +16°C and not exceed the temperature

indicated on the climate class label ([Chapter 2.2](#)), for which the equipment is intended.

- The equipment works immediately after connecting to the electrical network. Any other use is considered inappropriate.
- The equipment is intended only for storing frozen products.
- In the event of a power outage, the stored goods must be checked by a responsible person.
- The equipment can be operated only with the cover closed. Icing may occur on the cooling surfaces. Otherwise, the required temperatures cannot be maintained.
- The lids can be opened for a short time only to load and unload the product. After that, they need to be completely closed again.
- With effective cooling, condensate or moisture contained in the air appears, freezing on the cooling surfaces. Therefore, it is necessary to regularly defrost the equipment manually.

Do not use heaters or sharp objects for defrosting. This may damage the equipment.

2. DESCRIPTION OF THE EQUIPMENT

2.1. STANDARDS AND DIRECTIVES

The product complies with the provisions of the following directives:

- Directive on machines, mechanisms and machine equipment 2006/42 / EU;
- Electromagnetic Compatibility Directive 2014 / 30EU;
- Directive on low-voltage equipment 2014 / 35EU.

Production at the enterprise is carried out in an integrated management system in accordance with the requirements of the standards

ISO 9001:2015;
ISO 1400:2015;
ISO 45001:2018, IDT.

Standards used in the design and manufacture of products:
EN ISO 23953-2:2015

2.2. TECHNICAL DATA



Fig. 2.2.1. Rating plate

When working with the equipment, it is necessary to observe the information on the sign. This is a sticker on the back of the equipment that contains important technical data.

1. Name of the showcase;
2. Voltage (V);

3. Frequency (Hz);
4. Class of protection (IP);
5. Maximum used power (W);
6. Climatic class of the showcase;
7. Net weight of the showcase (kg);
8. Mass of refrigerant (g)
9. Type of refrigerant;
10. Temperature class inside the showcase;
11. Inventory number;
12. Date of manufacture;
13. Serial number;
14. Country of manufacture and certification marks;
15. Conditions of conformity of products (TU);

Examples of climate classes

| Climatic class according to ISO 23953-2 | Ambient temperature, °C | Relative humidity, % |
|---|-------------------------|----------------------|
| 3 | 25 | 60 |
| 4 | 30 | 55 |

2. 3. PACKAGE AND FUNCTIONS

The delivery set includes:

1. Refrigerated showcase.
2. Shelves/lattices.
3. Operating Instructions.
4. Passport.
5. Equipment for removing frost (scraper, etc.).

The equipment is suitable for storing prepackaged chilled or prepackaged deep-frozen products.

All equipment is delivered ready to work and has its own control unit.

The equipment is pre-programmed at the factory.

Equipment equipped with a mechanical thermostat is designed for deep freezing mode

Equipment equipped with an electronic thermostat is designed for cooling mode or deep freezing mode.

Switching between operating modes is carried out using the controller.

Equipment with an electronic thermostat has an automatic defrost function.

Defrosting occurs at regular intervals. The operator can also enable semi-automatic defrosting.

2. 4. AUTOMATIC DEFROSTING

The equipment has an automatic defrost function.

The frequency, duration and interval of the defrost start are set by the manufacturer at the factory.



Defrost frequency :

— 1 time a day (or according to the customer's requirements)

Duration of thawing

— Up to 50 minutes.

During automatic defrosting, the corresponding indicators and symbols are shown on the display

| Thermostat | Display indication | Symbol |
|---------------------|--------------------|---|
| Danfoss ERC112C | <i>dEF</i> |  |
| Danfoss ERC112d VSC | <i>dEF</i> |  |

The melt water formed in the internal volume of the unit is diverted to a heated bath, where it evaporates.

The defrosting process can lead to a slight increase in the temperature on the thermostat indicator.



WARNING! Leakage of melt water.

- Do not allow the formation of puddles in front of and under the unit;
- Remove the melted water that has leaked out immediately;
- Contact the service department.

3. CONTROL ELEMENTS

The display temperature is set at the factory to maintain the temperature class/mode of the product specified by the manufacturer.

To ensure optimal storage temperature, it is recommended to save the settings.

A change in the temperature regime can lead to spoilage of the product.

3.1. MECHANICAL THERMOSTAT

The temperature regulator (thermostat) is located on the side of the ventilation grill (Fig. 1).



Fig. 3.1.1. The location of the thermostat in the side ventilation grille.

Thermostat settings:

Level 1: The warmest mode

Level 6: Factory settings (depends on the customer)

Level 9: The coldest mode

To set the desired temperature, turn the thermostat (plastic handle).

- clockwise for lower temperatures
- against the time for higher temperatures





3.2. DANFOSS ELECTRONIC TEMPERATURE REGULATOR

Monitoring of compliance with the temperature regime is carried out using the Danfoss electronic controller ERC 112 C .



Fig. 3.1.2: Control elements of the Danfoss controller ERC 112 C.

Control elements are buttons programmed as follows:





| Button | Function |
|---|--|
|  | Short press: Increasing the set temperature (settings) defrost mode switch |
|  | Short press: Reduction of the set temperature (settings) defrost mode switch |
|  | Short press: not used; Long press: Enter the information menu |
|  | Short press: light switch (option) Long press: on/off |

Changing the set temperature (setting) :

1. The display shows the current temperature in the middle
2. Press "Up /Down" to access the set temperature (settings)
3. Press "Up /Down" to change the set temperature (setting). After 30 sec. the display will automatically return to the current temperature.



Fig. 3.1.3: Display indication.





| Display indication | According to the display indication |
|---|---|
| -000 | Temperature in volume. Operating mode code |
|  | The cooling function is active |
|  | Defrosting is active |
|  | The evaporator fan is active |
|  | Emergency signal |

3.3. ELIWELL ELECTRONIC TEMPERATURE REGULATOR

controller is placed on the front panel. Control elements are buttons (Fig. 2), which are programmed as follows:



Fig. 3.3.1. Indication and control elements of the controller Eliwell.

| Control element | Functions |
|--|---|
|  Up | Increase variable value Scrolling through menu items |
|  Down | Decrement the variable value Scrolling through menu items |
|  Escape | Return to the previous menu level Confirm the new value Long-term hold (5 sec.) Starting and exiting Standby mode |
|  Enter | Display of accidents Opening the main menu Long-term hold (5 sec.) Opening the programming menu Command confirmation |

Press the "Enter" button to display the set value.

Changing the set value:

Press the "Enter" button. The setpoint value will appear on the display.

Press the "Up"/"Down" keys to change the set value. Press the "Enter" button to confirm the changes.

4. UNPACKING AND INSTALLATION

Before and after unpacking the equipment, it is necessary to conduct a visual inspection to detect possible damage during transportation.

Pay attention to loose parts, dents, scratches, etc. If any damage is detected, the supplier must be notified before commissioning.

When installed, pay attention to the following points:

- Make sure that the equipment is installed stably and horizontally.
- The ventilation holes (grid) of the equipment must be clean. Install the equipment in a well-ventilated area.
- When installing the equipment, observe minimum distances of at least 100 mm from walls and other equipment.
- Avoid drafts and excessive heat radiation at the installation site. Do not place the equipment near radiators, heaters, under air conditioners and ventilation ducts.

4.1. PROCEDURE FOR ASSEMBLY OF INTERNAL GRILLS.

1. Two longitudinal mirror grilles with a step are installed in the internal space of the showcase from the side of the aggregate compartment (Fig. 4.1.1) . This connection is universal for all types of showcases

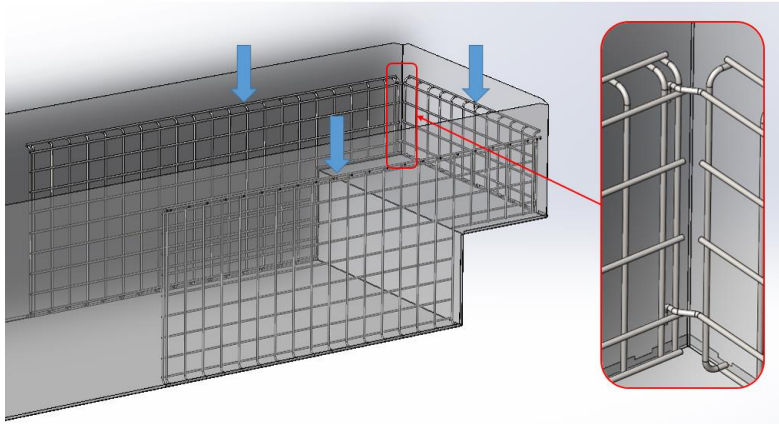

Fig. 4.1.1. The procedure for installing grids.

2. Two longitudinal gratings and end gratings are installed on the left wall of the internal space, they are attached to the longitudinal one (see Fig. 4.1.2)

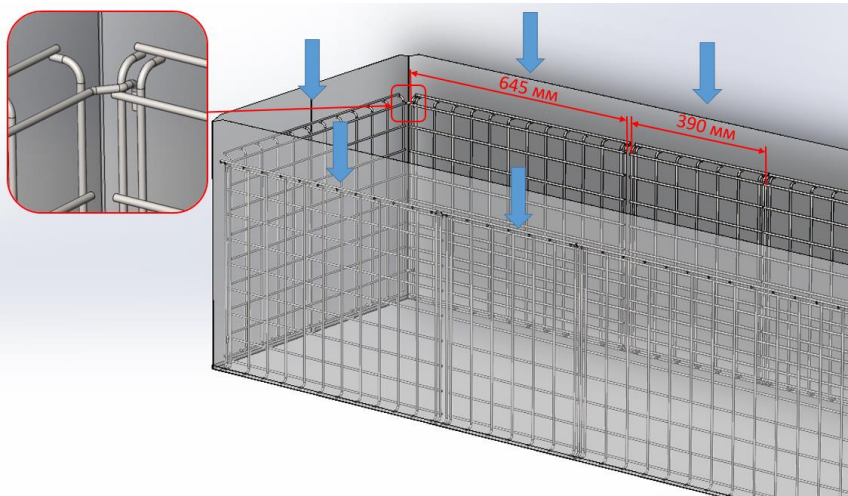

Fig . 4.1.2. Fastening of longitudinal and end gratings.

3. We install partitions designed to divide the internal space. The design allows you to arbitrarily adjust the width of sections, especially the layout of the product (Fig. 4.1.3).

The number of partitions depends on the size of the showcase and the customer 's requirements.

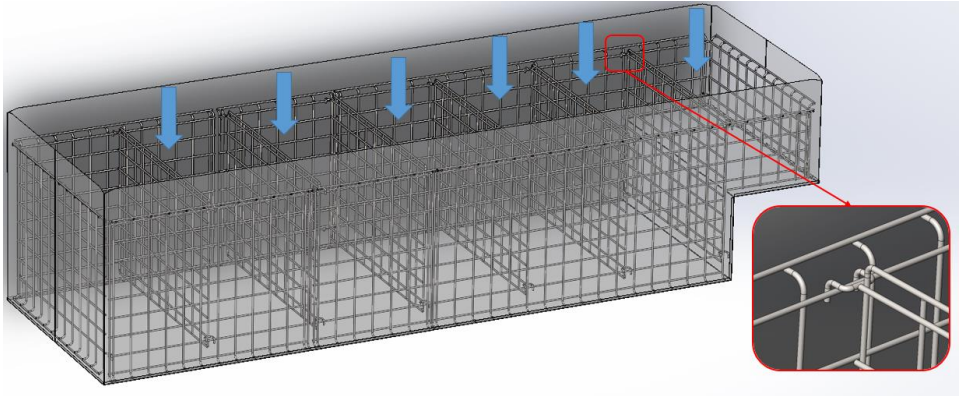

Fig. 4.1.3. Installation of partitions.

4. Horizontal grids are installed (Fig. 4.1.4) . They are adjustable in height.

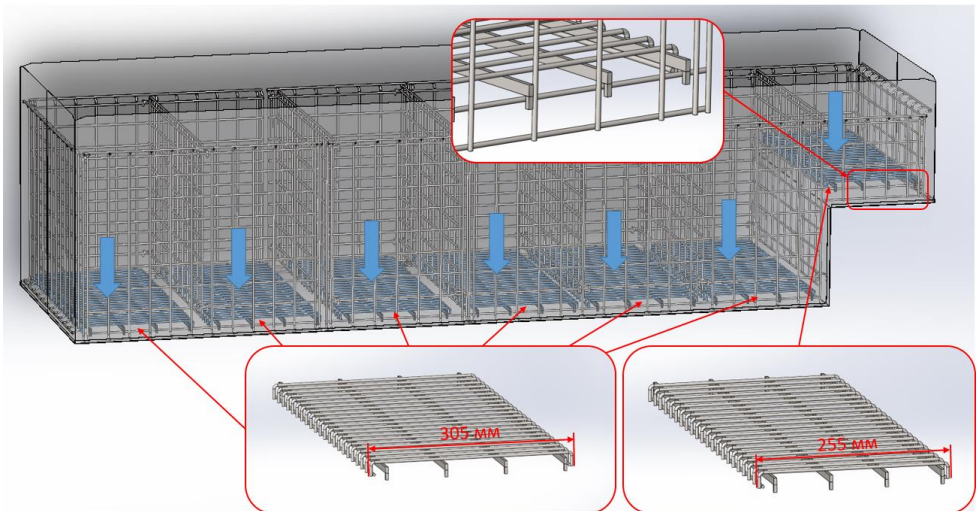

Figure 4.1.4. Horizontal bars

4.2. LOCATION AND ASSEMBLY PROCEDURE IN THE "ISLAND" SCHEME

1. Mount the brackets on the back panel (Fig. 4.2.1).

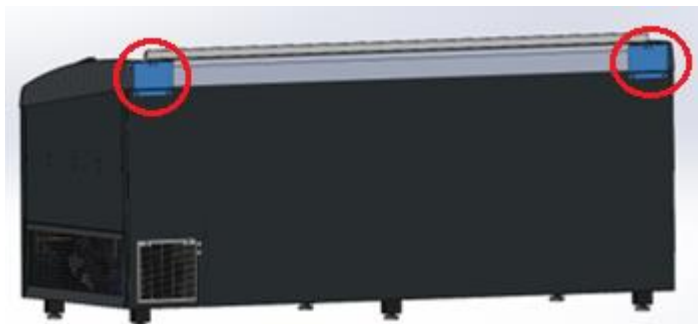
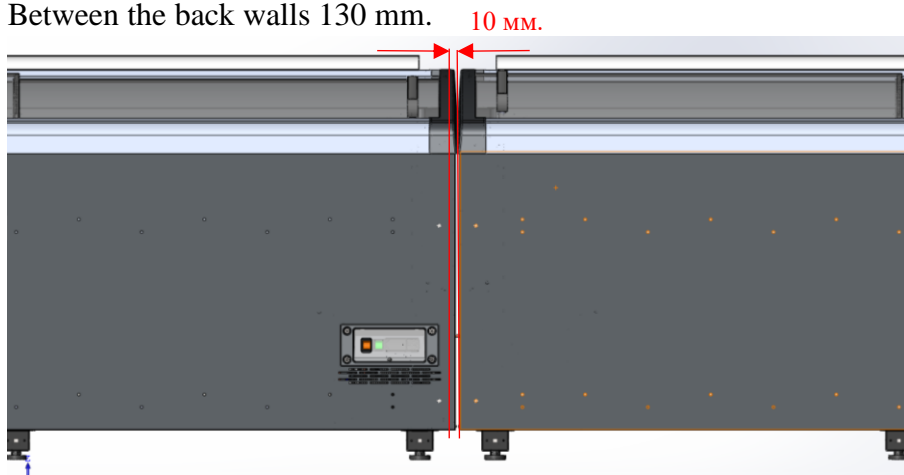

Fig. 4.2.1. Placement of brackets.

2. When installing showcases in the "island", observe the minimum distances (see Fig. 4.2.2, a, b).

- Between the side walls 10 mm;
- Between the back walls 130 mm.



a)

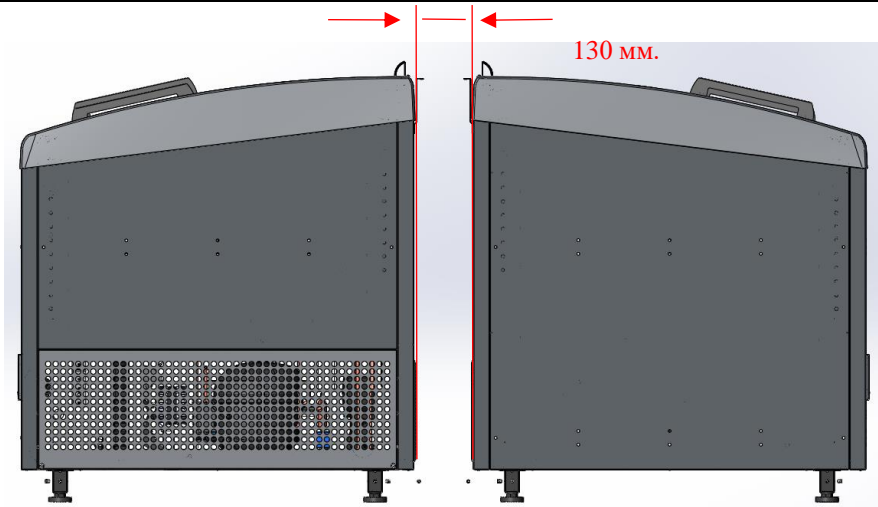

b)

Fig. 4.2.2. a) the minimum distance between the side walls; b) the minimum distance between the rear walls.

3. The panels of the pilasters are installed: the front, the end and the connector of the pilasters to the brackets on the legs of the bonnet (Fig. 4.2.3).

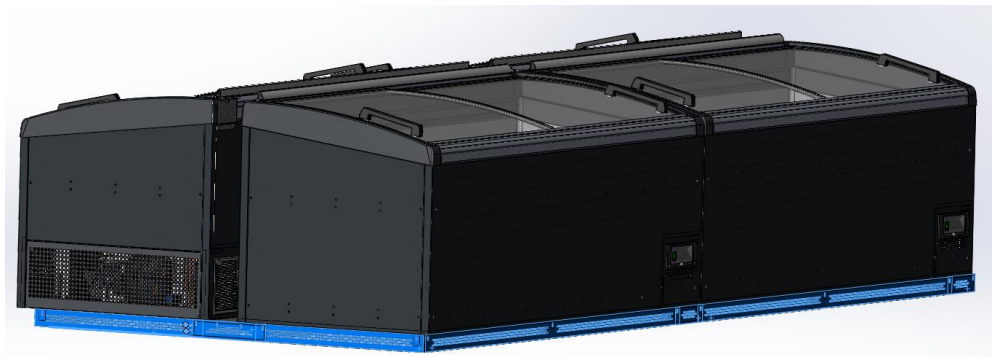

Fig. 4.2.3. Installation of safety guards.

4. The end insert is installed on the bracket and fixed from below with screws to the file connector (Fig. 4.2.4).

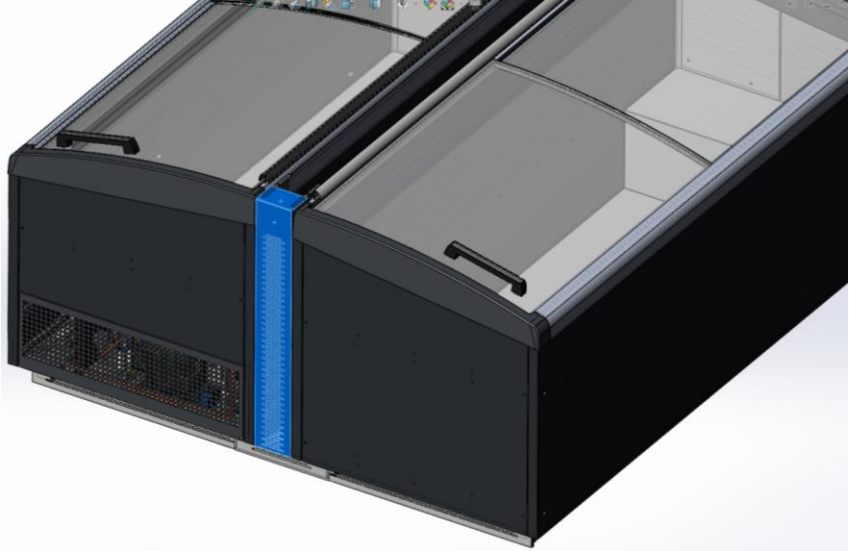

Figure 4.2.4. End insert.

5. A trapezoidal cover is installed on the brackets, a plug is installed on top and between them (Fig. 4.2.5).



Fig. 4.2.5. Trapezoidal cover.

6. On the end showcases, a plastic overlay is mounted, and then the panels of the dustpans are installed and connected to other showcases (Fig. 4.2.6).

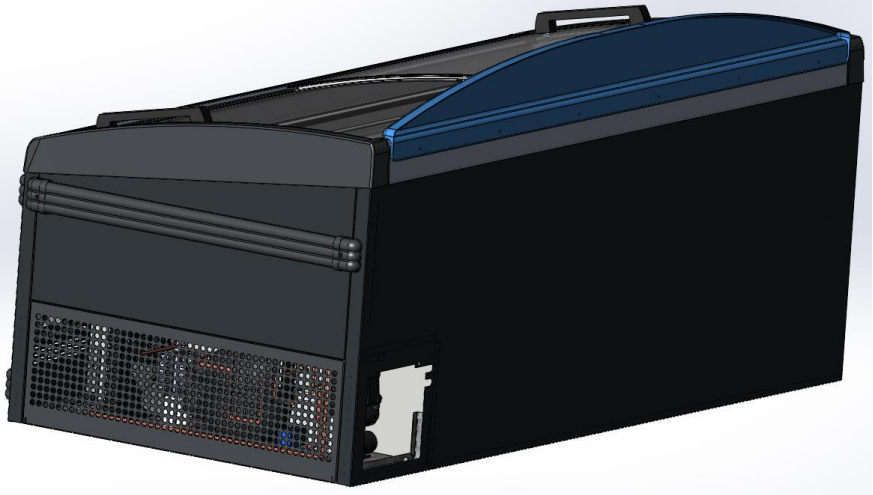

Fig. 4.2.6. Decorative overlay.

5. LOADING

The equipment can be loaded with the product only after reaching the temperature corresponding to the storage conditions of the product. Loading is allowed only up to the "loading line" mark on the inner wall (see Fig. 5.1)



Fig. 5.1. Loading line sticker

The specified storage temperature of the product above the loading line is not guaranteed.

6. DECOMMISSIONING AND STORAGE.

Decommissioning should be performed only by qualified service personnel.

Decommissioning procedure:

1. Move the product to another equipment with a suitable temperature regime.
2. Turn off the equipment from the network.
3. Clean the equipment.
4. Leave the lids open.

In case of long-term decommissioning:

- Do not expose the equipment to direct sunlight/heat
- Store the equipment only in a horizontal position.

7. CLEANING

Reasons for regular and thorough cleaning:

- Ensuring trouble-free operation;
- Minimum possible energy consumption;
- Extending the service life of the equipment.

Cleaning process:

1. Move the product to another freezer display.
2. Disconnect the power cable.
3. Open the lid for better defrosting.
4. Take out baskets or partitions.

5. Remove the melted water.
6. Remove any remaining product that has been stored
7. Wash the equipment using the manufacturer's recommended detergents and equipment.
8. Wipe the device dry.
9. Put back the baskets or partitions.
10. Connect the power cable to the electrical network.
11. Wait for the required temperature to store the product.
12. The product can be stored again.

We recommend using detergents:

| Detergent | Cleaning area |
|---|--|
| Clean water | External and internal surfaces of the equipment. External and internal glass surfaces |
| Detergents (eg soap and water) in case of heavy contamination | External and internal surfaces of the equipment. External glass surfaces |
| Windscreen wiper | External glass surfaces |

When cleaning, use the following equipment:

| Cleaning supplies | Cleaning area |
|----------------------------------|--|
| Wet soft cotton fabric | External and internal surfaces of the equipment. External and internal glass surfaces |
| A damp absorbent cloth or sponge | External and internal surfaces of the equipment. External and internal glass surfaces |
| For drying | |
| Wet soft cotton fabric | External and internal surfaces of the equipment. External and internal glass surfaces |

8. DISPOSAL



Improper disposal harms the environment.

- Pay attention to the safe disposal of refrigerant, insulating foam (polyurethane foam), compressor oil, power supply unit.
- Dispose of the equipment properly in accordance with applicable national disposal regulations and the regulations of your local disposal partner.
- Devices cannot be disposed of together with household waste.

| Authorized service | |
|--|---|
| <p>Poland: UBC Logistyka Sp. z o. o BYKOW, UL. GAJOWA 5 55-095 MIRKOW Wojtek Rytkowski tel.: +48717400076 / tel. kom.: +48603227267 e-mail: w.rytkowski@beer-co.com</p> | <p>Bosnia : NICROM COOLING DOO Milana Vrhovca 79, 79101 Prijedor, Republika Srpska, Bosnia and Herzegovina Dragan Tankosic tel.:+38752213213 e-mail: dragan.tankosic@nicromcooling.com</p> |
| <p>Czech: ViGo-servis sro Havlíčkova 303 289 12 Třebestovice phone: +420603295770 e-mail: vigo.psenikka@trebestovice.cz</p> | <p>Croatia, Slovenia : BEVERAGES SERVIS DOO Slavonska avenija 24/A, 10000, Zagreb, Croatia Endre Katona tel.: +385914390830 e-mail: endre.katona@beverages.hr</p> |
| <p>Slovakia: Chladservis KP, sro Bottova 347/16 953 01 Zlaté Moravce phone: +421 903 119 163 e-mail: info@chladserviskp.sk</p> | <p>France: Interfroid services 143 Bd Pierre Lefauchaux - 72230 France Johann JOUANNEAU phone: 0243892926 e-mail: Johann.jouanneau@interfroidservices.fr</p> |
| <p>Hungary: THERMOTECHNIKA CROWN COOL HU: H1103 Budapest, Köér u. 3/F. Zoltan Peszleg phone: +36304757022 e-mail: peszleg.zoltan@tchungary.com</p> | <p>Germany: KTO GmbH Alte R ö merstra ß e 9, 56154 Boppard - Buchholz Simon Saß phone: +49 06742804828 e-mail: Simon.Sass@KTOGmbH.de</p> |
| <p>Greece: UNIOR Srl Via Collodi, 4/g 40012 Calderara di Reno Bologna - Italy</p> | <p>Lithuania, Latvia: UAB "VR Servisas" Sandėlių g. 40 Klaipėda, Lithuania Robertas Skurdenis</p> |

| | |
|---|--|
| <p>Luca Pancaldi Tel. +39 051 6467027 (10 linee ra) E-mail: l.pancaldi@unior-service.com</p> | <p>phone: +370 656 07507 e-mail: info@vrservisas.lt</p> |
| <p>Bulgaria: Ice Technic Ltd 1225 Sofia 61 Zhelezopata Str. Vladimir Dimitrov tel.: +359888629539 e- mail: vladimir@icetechnic.com</p> | <p>Italy: UNIOR Srl Via Collodi, 4/g 40012 Calderara di Reno Bologna – Italy Luca Pancaldi tel. +39 051 6467027 (10 linee ra) e-mail: l.pancaldi@unior-service.com</p> |
| <p>Serbia: COOL BEER DOO Crkvište 5a, 11210 Krnjača Duško Rađen te+381654977001 dusko.radjen@coolbeer.co.rs</p> | <p>Rumania: THERMOTECHNIKA CROWN COOL RO: str Toplița, nr. 155, Miercurea Ciuc Csaba Balint phone: +40266317827 e-mail: csbalint@tcromania.com</p> |
| <p>Ukraine: UBC Service Address: Kharkiv, Selyanka 110, Ukraine Contact person: Andriy Maydan Phone: +380503476869 e-mail: a.maydan@beer-co.com</p> | <p>Kazakhstan: UBC Service Address: ZHETUSU AUDANA, PRO. Suyinbai, 2, phone: +77777767010 e-mail: almaty@beer-co.com</p> |
| <p>Manufacturer address : LLC "GREEN COOL", st. Nemyrivske Shosse, 213, Vinnytsia, Vinnytsia region, Ukraine.</p> | |